

WESTERN BLOTTING PROTOCOL (Denatured, Reducing/Non-reducing)

Based on Kiki, Barbi Sódar and Sz.T. Kata with minor modification by Tamás and Anna

I. EV SAMPLE PREPARATION FOR WB

- EV separation
- Re-suspend the EV pellet in lysis buffer (RIPA/commercial cell lysis buffer/etc..) containing protease inhibitors (between 30ul and 200ul depending the pellet)
Store the lysis buffer and protease inhibitors on ice! Add the inhibitors freshly to the lysis buffer.
See in details: [Protease inhibitor panel \(Kiki\)](#)
- Incubate for 30min on ice (vortex approx. 3 times/30min) and vortex between each time.
- Centrifuge for 15 min at 10.000g at 4C
- Aspirate the supernatant and place in a fresh tube (discard the pellet..)
- Use it freshly or store at -20°C or for longer time at -80C
- Determine the protein concentration of the samples – microBCA (*see it later*)
(Generally, the optimal amount of protein to run per lane is 20-50 µg total protein/lane in the case of mini gels) but also work with 10ul depending of the gel.

I. BUFFERS

-Better to do the buffer the day before and keep it in the frig

Laemmli buffer (WB sample loading buffer):

Commercial 2x Laemmli (bioRad)

Add β-mercaptoethanol (5v/v% final concentration/710mM) or DTT (350mM) if it's needed (to reducing PAGE)

Home-made 5x Laemmli buffer recipe (Kiki):

0,5 M Tris-HCL; pH:6.8	1,75 mL
Glycerol	4,5 mL
SDS (0.25 g / 1 mL Tris HCL pH:6.8)	2 mL (0,5 g)
0.25 w/v% bromophenol blue solution (25 mg in 10 mL ddH2O)	0,5 mL
B-mercapto-ethanol	1,25 mL
total	10 mL

Store the aliquots at -20°C

10x Running buffer:

10 X RUNNING PUFFER: 0.250 M Tris, 1.92 M glycine, 1% w/v SDS, pH 8.3			
10x puffer:	MW	to 1 L 10xbuffer	
Tris	121.14 g/mol	30 g	
glycine	75 g/mol	144 g	
SDS	288.38 g/mol	10g	
ddH2O		to 1 L	

Adjust the pH with HCl if it's needed.

Can be stored at RT for a long time.

Dilute in precooled (4°C) ddH₂O to 1X immediately before use.

10x Towbin Transfer/Blotting buffer - ONLY for WET BLOTTING

10 X BLOTTING PUFFER: 0.25 M Tris, 1.92 M glycine, pH 8.3			
10x buffer	MW	to 1L 10xbuffer	
Tris-base	121.14 g/mol	30.3 g	
glycine	75 g/mol	144 g	
ddH₂O		to 1L	

Adjust the pH with HCl if it's needed.

TAMAS recommendation: Be careful with TRIS base or HCL as PH can be different

Can be stored at RT for a long time.

Dilute in precooled ddH₂O before use.

1L 1x buffer: 100mL 10x buffer

200mL methanol

700mL precooled ddH₂O

1x Transfer buffer - ONLY for SEMI-DRY BLOTTING

1X BLOTTING PUFFER: 0.48 M Tris, 0.39 M glycine			
1x buffer	MW	to 1L 10xbuffer	
Tris-base	121.14 g/mol	5.76 g	
glycine	75 g/mol	2.95 g	
methanol		200 mL	
ddH₂O		to 1L	

Adjust the pH with HCl if it's needed.

Prepare 1x before use.

TBS-0.1% Tween: 1000µl Tween + 1 L 1x TBS

Blocking buffer 5% milk-TBS-Tween: -2,5 g non-fat dry milk (TUTTI sovany tejpor- Groby) + 50 ml TBS. Dissolve under rotation. Filter with 70 µm or 40µm cell strainer. Add 50µL Tween20 to 50mL solution. (5% milk-TBS 0,1% Tween).

You can use BSA solution or caseine or commercial blocking buffers.

KIKI recommendation : if you use biotinylated antibody then do not use milk

PREPARATION OF POLYACRYLAMIDE GEL/ USE COMMERCIAL GELS

Infos about precast gels: Kiki

Usage: <https://www.bio-rad.com/en-hu/category/mini-protean-precast-gels?ID=N3GRRS15>

Rule of thumb: The smaller the size of the protein of interest, the higher the percentage of mono/bis. The bigger the size of the protein of interest, the lower the percentage of mono/bis.

Protein size (kDa)	Gel percentage (%)
4-40	20
12-45	15
10-70	12.5
15-100	10
25-200	8

PREPARE 10X BUFFERS AND PRECOOL 2X1L DDH₂O A DAY BEFORE

PREPARATION OF SAMPLES

- Thaw samples on ice and vortex
- Mix with appropriate amount of Laemmli buffer
Or with Laemmli and Triton-X.
f.ex.: Laemmli (3x) : 0.1% Triton-X : EV sample (1:1:1) for exemple : 5ul Laemmli (3x)+5ul Triton+5ul EV (for membrane proteins)- (cite TAMAS PAPER : T.visnovitz and A.Solti 2012)
- Vortex thoroughly/Sonicate (in precooled sonicator) for 10 min
- Boil the mixture at 95°C for 5min (under the fume hood!)
- Centrifuge for 10 min at 10.000g
- Samples can be stored at -20°C for later usage

SDS PAGE/RUNNING THE GEL /

- Assemble the electrophoresis system:
BioRad Mini-Protean system:

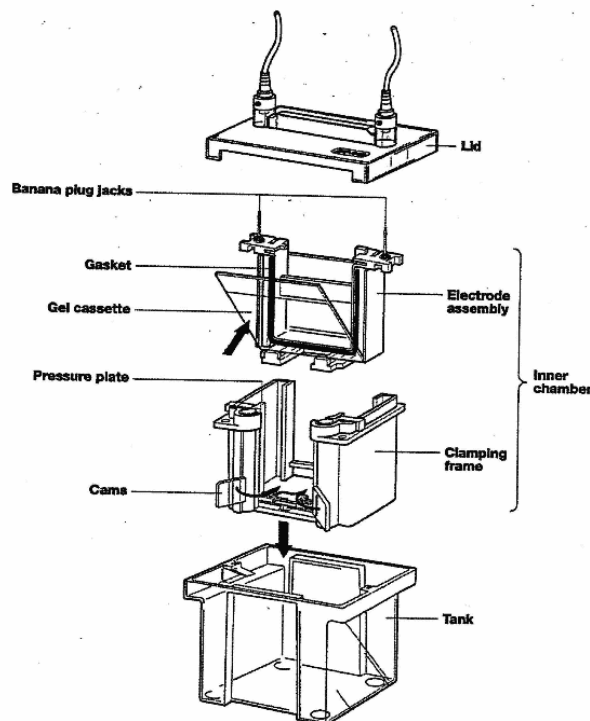

- Place the gels into the equipment, remove combs carefully and fill the tank with 1xRunning buffer (gel must be covered). If you have just 1 gel, then put a special glass plate to the other side.
- Wash the wells with running buffer
- Load the samples and the molecular weight marker (f.ex.: Spectra Multicolor Broad Range Protein Ladder, Thermo).
If 0.1% Tx was used to the sample loading mix, then add to the marker solution too! For exemple here add 5ul to the sample.

maximum sample volumes you can load in the wells of different gels:

max minta térfogatok				
Mini gélek	fésű			
	5	70 ul	105 ul	160 ul
	10	33 ul	44 ul	66 ul
	15	20 ul	26 ul	40 ul

fesu = comb

- Run the gel 150V through the stacking gel and 100-120 V through the resolving gel
- Turn off the power when the dye molecule (blue “migration front”) reaches the bottom of the gel
- Disassemble the electrophoresis system. Put the gel immediately to ddH₂O.
- Wash the tank with ddH₂O (**NEVER WASH IT WITH ALCOHOL!!**)

VISUALISATION OF PROTEINS IN GEL (IRREVERSIBLE)

To check for success of SDS-PAGE (or transfer, after blotting) wash the gel with ddH₂O and incubate in Coomassie staining solution in a staining container 4 hours to O/N at RT under agitation. Transfer the gel to Washing solution place on shaker, and replace with fresh mixture until the excess dye has been removed.

Coomassie Brilliant Blue staining solution

recipe:<http://cshprotocols.cshlp.org/content/2007/2/pdb.rec10727.full?sid=31042e6f-961c-4f6b-88b2-2b165940264d>

Destaining solution

recipe:<http://cshprotocols.cshlp.org/content/2007/4/pdb.rec10932.full?sid=31042e6f-961c-4f6b-88b2-2b165940264d>

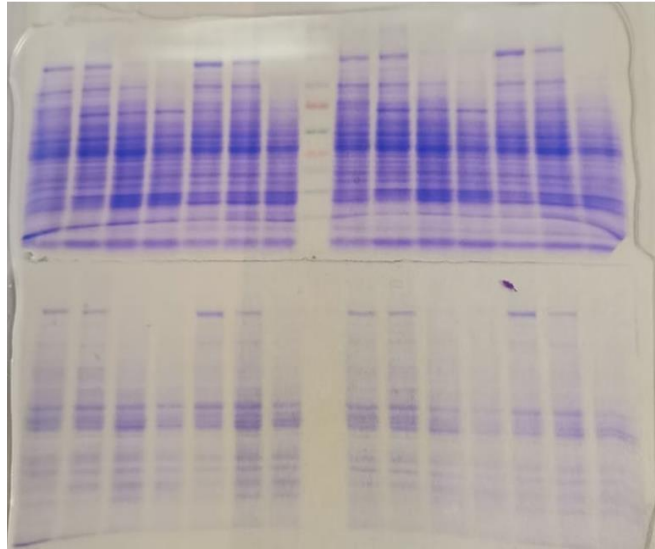

III. BLOTTING

You have the choice between wet blotting and semi-dry blotting. Wet blotting is fail-safe and the gold standard, but with most applications, and proteins not too large or too small, semi-dry blotting will also work fine, and is cheaper, faster, less messy.

For semi-dry blotting:

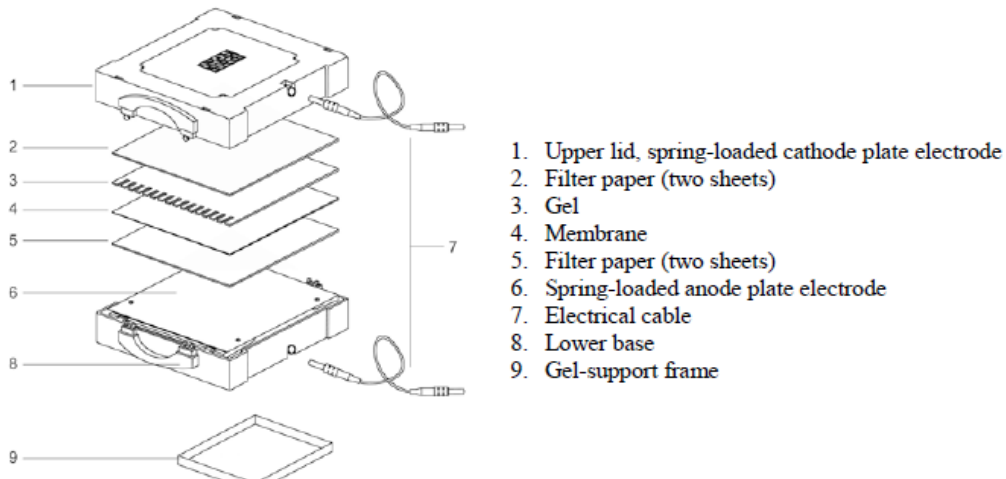

- run the blot at 25 V for 40 min

TAMAS recommendation: if you use semi-dry so you should not use Nitrocellulose membrane.

For wet-blotting prepare 1x transfer buffer

- Prepare the PVDF membrane (0.2 μm , 26.5 cm x 3.75 m, Thermo, #88520), cut the membrane to size (! **Always handle using gloves!**).

- Activate PVDF with methanol for 10-20sec (immerse with plastic forceps) then put it into ddH₂O for 5 min. Transfer the wetted membrane to transfer buffer. Incubate in transfer buffer up to 15 min (equilibration).

After it is equilibrated it can be easily submerged into the aqueous solution. At this point, the membrane is ready to bind proteins.

- Soak all apparatus (fiber pad, filter papers, etc.) in transfer buffer
- Wash the gel in ddH₂O then incubate for 15 min in transfer buffer (equilibration) for wet blotting
- Assemble the blot sandwich/stack under transfer buffer

WET BLOTTING

(Assemble the sandwich on the black side of the apparatus, then place **black to black** in tank).

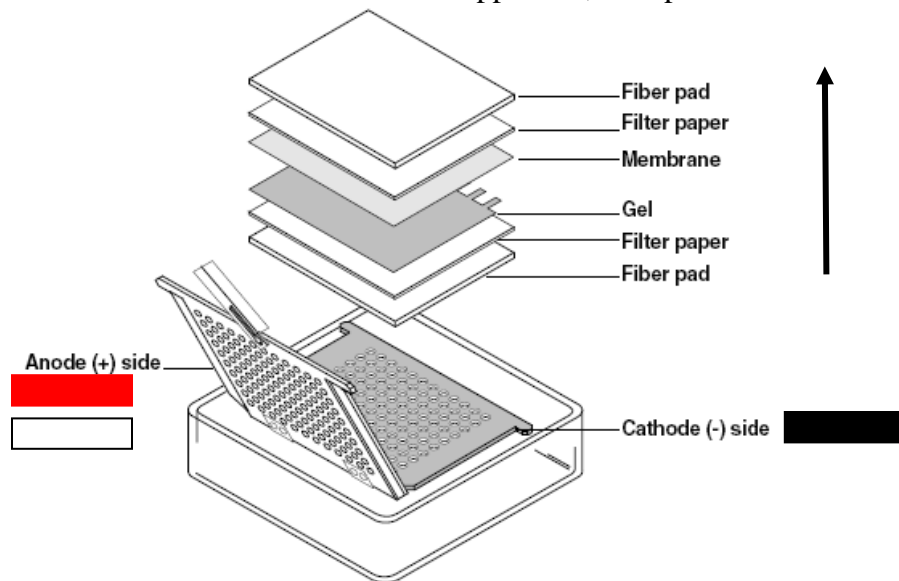

- Roll the surface of the filter paper above the membrane with the roller, to exclude all air bubbles
- fill blot tank to the top with cooled 1x transfer buffer (ensure that membrane is fully covered)

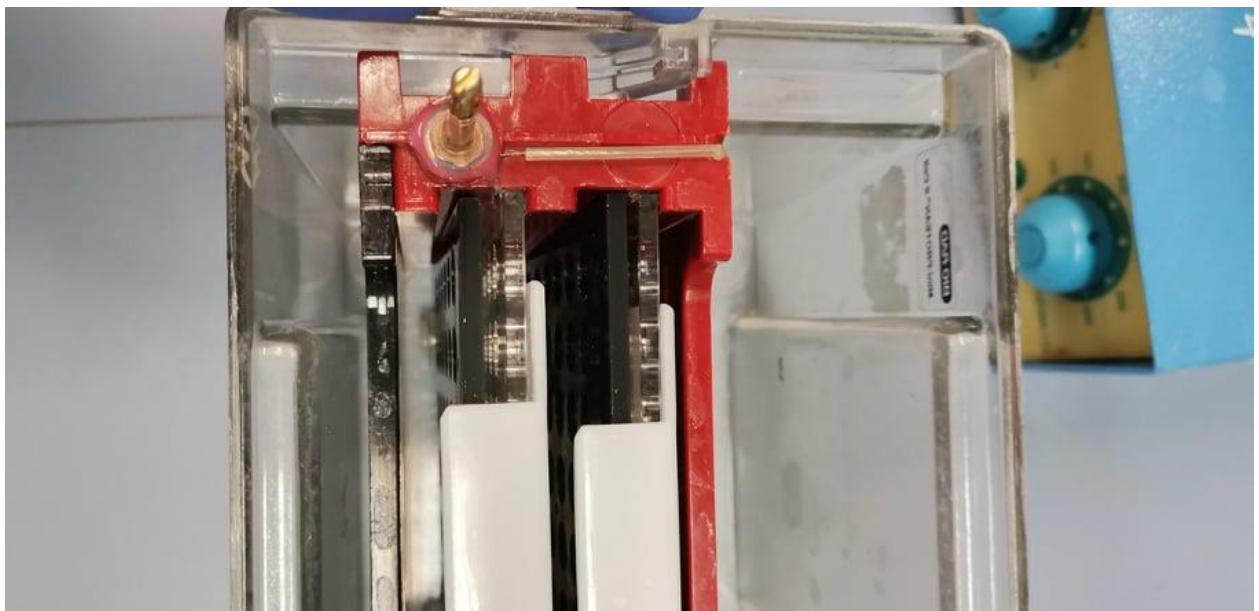

- blot at 80-90V for 1 hour on ice (*gold standard*)

After blotting:

- Disassemble the sandwich and rinse the membrane in TBS-Tween

Take care of the side of the membrane that you put in 50ml tube for AB incubation as the side which touch the gel is where the proteins are.

VISUALISATION OF PROTEINS IN MEMBRANE (REVERSIBLE)

To check for success of transfer, wash the membrane in TBS-Tween and stain with Ponceau S solution.

Incubate on an agitator for 5 min.

Wash extensively in water until the water is clear and the protein bands are well-defined.

The membrane may be destained completely by repeated washing in TBS-Tween or water.

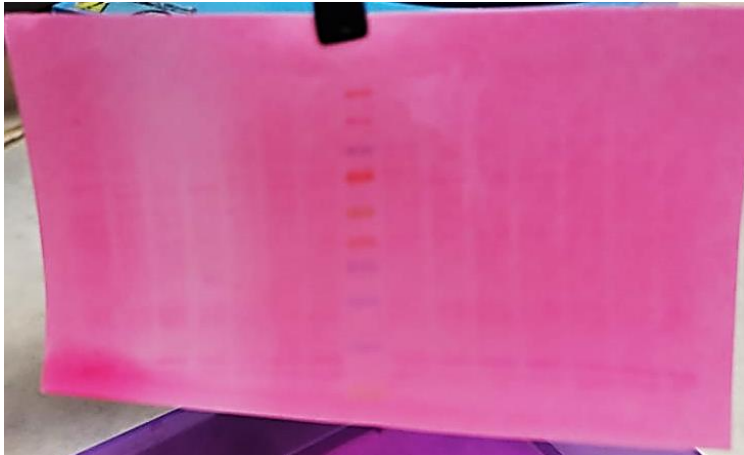

KIKI recommendation : Or UV detection with Sypro on membranes or on gels

- Block the membrane with 5% milk –TBS-Tween (Blocking buffer) for at least 1 h at RT under agitation or rotation
50 mL Falcon tubes/15mL Falcon tubes can be used
- Wash the membrane in TBS-Tween
Possible point to finish the day earlier: The membrane can be stored in 4°C in TBS-Tween, but in this case it's recommended to start with a repeated blocking.
- Incubate with primary antibody in in 5% milk –TBS-Tween (Blocking buffer) overnight at 4 °C or 1 h RT under rotation
Find the recommended dilution of primary antibody on datasheet. Always worth to start with that concentration and optimize further if it's needed.
Try different blocking buffers (caseine, BSA, etc)
- wash blot 6x5 min in TBS-Tween under rotation
- incubate with secondary antibody (HRP conjugated) in 1% milk –TBS-Tween – 1 hour RT under rotation.

- wash extensively – 3x10 min in TBS-Tween
- Membranes can be stored in TBS-Tween at 4C for further usage

DETECTION WITH ECL REAGENT

- Incubate in ECL reagent (Pierce/BioRad)/cover the surface with ECL reagent for 1-5 min before detection (VWR geldoc system in the big lab/708 room- use the black plate!).

After detection, wash the membrane with TBS-Tween under rotation.

The membrane can be stored at 4°C in TBS-Tween for some weeks (months- TBS (without Tween)+ add azide).